

LOW LIFT TRUCK

EKseries



国内初!リチウムイオンバッテリー搭載。
しかも超ローコスト!

It is compact and runs for a long time.
Lithium battery installed.



充電時間
約4時間

Charging time
4 hours



稼働時間
約3.5時間

※ コレック20m/パターンサイクル
稼働率100%

Operating time
3.5 hours

Note: In case of 100% operation
in KOLEC's 20 m pattern cycle.

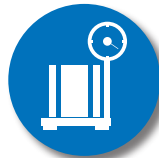

最大荷重
1,500kg

Maximum load
1,500kg

超コンパクト
Compact

無段階変速
Seamless speed control

メンテナンスフリー
Maintenance-free

※ ブラシレスモータ採用
※ リチウムイオンバッテリー搭載
Note: Brushless motor mounted
Note: Plug-in battery adopted





充電時間
約4時間

Charging time
4 hours



稼働時間
約3.5時間

※ コレック20mパターン
サイクル稼働率100%

Operating time
3.5 hours
Note: In case of 100% operation
in KOLEC's 20 m pattern cycle.



最大荷重
1,500kg

Maximum load
1,500kg

- 電動走行 Electric travel
- 電動上昇 Electric lift
- バッテリーインジケーター Battery indicator
- 挟まれ防止スイッチ Safety switch
- 10秒でバッテリー交換可能
10 seconds replacement of the battery
(Second set of battery can make 24 hours of
continuous operation).
- 超コンパクト
ハンドパレットトラックの全長+106mm
※弊社ND15-510比
Total length of hand pallet truck + 106 mm
Note: Compared to ND15-510



上昇ボタン
Up switch

下降レバー
(下降スピード調整可能)
Down lever

キースイッチ
Key switch

バッテリー
インジケーター
Battery
indicator

ハンドル手元側
Handle

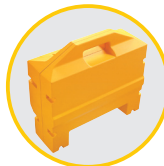

カートリッジ式
リチウムバッテリー
(メンテナンスフリー)
48V 約10kg
Plug-in battery
(Maintenance-free)
48V 10kg



・ブラシレスモーター
+電磁ブレーキ
(メンテナンスフリー)
・Brushless motor
+Electromagnetic Brake
(Maintenance-free)



定置式充電器
Charger



option
予備バッテリー
Spare battery

Model	EK15L-B1	
Maximum Load	1500kg	
Driving Speed (Laden/Unladen)	4.8km/h · 5.0km/h	
Minimum Turning Radius	R	1494mm
Length	L	1693mm
Width	685mm	
Heihgt	1200mm	
Fork Length	F1	1220mm
	F2	930mm
Fork Overall Width	W1	685mm
Single Fork Width	W2	160mm
Minimum Fork Height	80mm	
Maximum Fork Height	190mm	
Drive Wheel	210×74mm	
Load Wheel	80×70mm	
Driving control	DC brushless motor chopper control	
Braking method	Electromagnetic brake	
Lift System	UP: Electric hydraulic DOWN: Manual handle	
Battery	48V 20Ah	
Battery Charger	Stationary Charger 100~240V	
Service weight	140kg	
Battery weight	10kg	

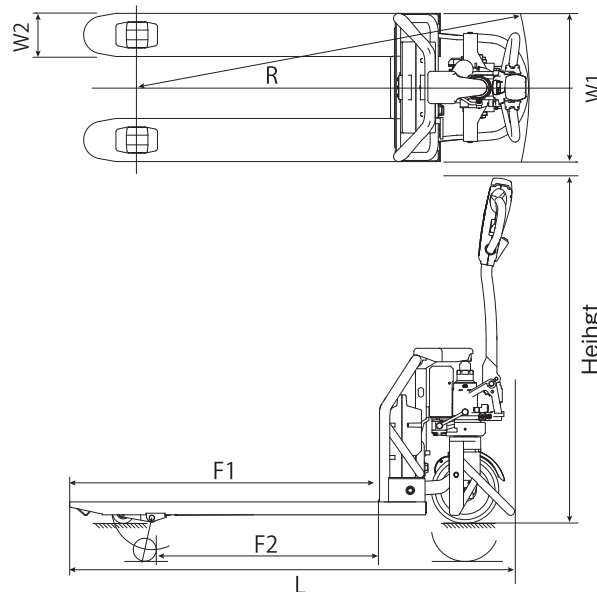

For product inquiries, please visit our website at <http://www.kolec.co.jp/en/> or contact below:



Nakanishi Metal Works Co.,Ltd.

NAKANISHI CONVEYORS ENGINEERING (M) SDN.BHD.

Lot 558, Jalan Subang 3, Sungai Penaga industrial park,
47610 Subang Jaya, Selangor Darul Ehsan, Malaysia.
TEL: 03-5638 1909/1910 FAX: 03-5635 1913
H/P: 012-918 1233
E-Mail: kolec@nkc.com.my / wang@nkc.com.my

Nakanishi Metal Works Co.,Ltd Head Office

3-3-5 Tenmabashi, Kita-ku, Osaka 530-8566
TEL: +81-6-6351-3280 FAX: +81-6-6351-8365

Shiga Plant/Parts Center

4 Hie-cho, Konan-shi, Shiga 520-3203
TEL: +81-748-75-7846 FAX: +81-748-75-7840



KOLEC is a brand of the material handling devices of
Nakanishi Metal Works Co., Ltd.

For inquiries, contact the dealer indicated below.



<http://www.kolec.co.jp/en/>